



SAN FRANCISCO PLANNING DEPARTMENT

MEMO

DATE: July 25, 2014
TO: Charles Muller
FROM: Joshua Switzky, Planning Department
RE: PPA Case No. 2014.0859U for 585 Bryant St

1650 Mission St.
Suite 400
San Francisco,
CA 94103-2479

Reception:
415.558.6378

Fax:
415.558.6409

Planning
Information:
415.558.6377

Please find the attached Preliminary Project Assessment (PPA) for the address listed above. You may contact the staff contact, Jeremy Shaw at (415) 575-9135 or jeremy.shaw@sfgov.org, to answer any questions you may have, or to schedule a follow-up meeting.



Joshua Switzky, Senior Planner



SAN FRANCISCO PLANNING DEPARTMENT

Preliminary Project Assessment

Date: July 22, 2014
Case No.: 2014.0859U
Project Address: 585 Bryant Street
Block/Lot: 3776/034, 038, 39, 042, 043, 044
Zoning: SLI
65-X
Area Plan: Eastern SoMa, Central SoMa
Project Sponsor: Charles Muller
Contact: John Kevlin
415-567-9000
jkevin@reubenlaw.com
Staff Contact: Jeremy Shaw – 415-575-9135
Jeremy.shaw@sfgov.org

1650 Mission St.
Suite 400
San Francisco,
CA 94103-2479

Reception:
415.558.6378

Fax:
415.558.6409

Planning
Information:
415.558.6377

DISCLAIMERS:

Please be advised that this determination does not constitute an application for development with the Planning Department. It also does not represent a complete review of the proposed project, a project approval of any kind, or in any way supersede any required Planning Department approvals listed below. The Planning Department may provide additional comments regarding the proposed project once the required applications listed below are submitted. While some approvals are granted by the Planning Department, some are at the discretion of other bodies, such as the Planning Commission or Historic Preservation Commission. Additionally, it is likely that the project will require approvals from other City agencies such as the Department of Building Inspection, Department of Public Works, Department of Public Health, and others. The information included herein is based on plans and information provided for this assessment and the Planning Code, General Plan, Planning Department policies, and local/state/federal regulations as of the date of this document, all of which are subject to change.

PROJECT DESCRIPTION:

The proposal is to build an 11-story, 211,000 square-foot mixed-use development on a group of contiguous parcels fronting on Bryant and Welsh Streets, mid-block between 3rd and 4th Streets. The project would consolidate six lots owned by the Sponsor (23,600 square feet of land) and demolish four structures (totaling approximately 17,000 square feet) used for auto repair services. The proposed building would contain nearly 47,000 square feet of office space, 112 dwelling units (52 1-br, 60 2-br), approximately 21,000 GSF of ground-floor commercial, publicly-accessible open space and rooftop open space. The basement level includes approximately 23,000 GSF for parking/mechanical areas. Parking access would be provided from Welsh Street. The existing building on lot 3776/034 was constructed in 1926 and the Welsh Street-fronting building on 3776/044 was built in 1929.

ENVIRONMENTAL REVIEW:

The proposed project is within the Central SoMa Plan area, which is a comprehensive plan for the southern portion of the Central Subway transit line, an extension of the Third Street light rail line, in the area bounded by Mission, Second, Townsend, and Sixth Streets. The Central SoMa Plan is currently

undergoing environmental review, and expected to be adopted in late 2015. The 565-585 Bryant Street project would be consistent with the rezoning proposed under the Central SoMa Plan.

To facilitate environmental review and comply with CEQA, the project sponsor for the proposed project can take **one of two approaches**:

(1) The project sponsor can submit an Environmental Evaluation Application during the period that the Central SoMa Plan is undergoing environmental review, and the information in the Environmental Evaluation Application must be supplemented with the background studies as noted below on p. 3-9. The standard environmental evaluation fee, which is based on construction value, must be paid at the time of filing of the Environmental Evaluation Application; or

(2) Because the proposed project at 565-585 Bryant Street is dependent on the rezoning under the Central SoMa Plan, environmental clearance for this project could also occur after certification of the Central SoMa Plan EIR and adoption of the Plan. If it is determined that the proposed project is consistent with the development density and other zoning parameters established by the adopted Central SoMa Plan, the proposed project could be eligible for Community Plan Exemption (CPE) from the California Environmental Quality Act (per CEQA Guidelines Section 15183). Within the CPE process, there could be three different outcomes for the proposed project as follows: (i) a stand-alone CPE, if all potentially significant project-specific and cumulatively considerable environmental impacts are fully consistent with significant impacts identified in the Central SoMa Plan EIR, and if there are no new significant impacts peculiar to the proposed project; (ii) a CPE + Focused Preliminary Mitigated Negative Declaration (PMND), if the project includes site- or project-specific impacts not identified in the Central SoMa Plan EIR that require mitigation measures that would reduce such impacts to less-than-significant levels; or (iii) a CPE + Focused Environmental Impact Report (EIR), if the proposed project would have significant and unavoidable environmental impacts that were not identified in the Central SoMa Plan EIR. For more information on the three possible outcomes with a CPE, see p. 9-10. The project sponsor would still need to submit an Environmental Evaluation Application for the CPE approach and the information in the Environmental Evaluation Application must be supplemented with the background studies as noted below on p. 3-9.

Under either environmental review approach, the cumulative analysis for the proposed project at 565-585 Bryant Street would be dependent on and need to be consistent with the cumulative analysis conducted for the Central SoMa Plan EIR. Environmental review for the proposed project under either approach would therefore need to be coordinated with environmental review and clearance for the Central SoMa Plan.

To facilitate environmental review and comply with CEQA, the project sponsor shall submit an Environmental Evaluation Application. The information in the Environmental Evaluation Application must be supplemented with the following background studies:

1. **Historic Resources.** The SoMa Area Historic Resource Survey, which was adopted by the Historic Preservation Commission on December 1, 2010, assessed 2,142 individual properties, in a project area roughly from Mission Street to Townsend Street, and between 1st and 13th Streets. The project site at 565-585 Bryant Street was one of the properties rated California Historical Resource Status Code 6Z, which represents properties deemed ineligible for National Register (NR), California Register (CR),

or Local designation through survey evaluation.^{1,2} The project site is not located in any existing or proposed historic district. Therefore, further historic architectural review would likely not be required for the proposed project.

- 2. Archeological Study.** The proposed sponsor has indicated that the amount or depth of soil disturbance involved in the proposed project is unknown at the time of this PPA. The project involves a construction of an approximately 24,000-sf basement level. The project site was determined to be a J-2 property in the Eastern Neighborhoods Rezoning and Area Plans FEIR (Eastern Neighborhoods FEIR).³ The Eastern Neighborhoods FEIR requires that a Preliminary Archeological Review (PAR) be undertaken for projects on J-2 properties, which are the properties for which no archeological assessment report has been prepared or for which the archeological documentation is incomplete or inadequate to serve as an evaluation of potential effects on archeological resources under CEQA.

Based on the above, it appears likely that a similar mitigation measure would be adopted in the Central SoMa Plan EIR, and that the project would be subject to PAR, which would be conducted in-house by the Planning Department Archeologist. The PAR would determine what type of soils disturbance/modification would result from the project, such as excavation, installation of foundations, soils improvement, site remediation, etc. Any available geotechnical report or Phase II ESA prepared for the project site would be reviewed as part of the archeological review for this project. In addition, it would also be determined if the project site is in an area that is archeologically sensitive. The result of this review would be provided in a memorandum to the environmental planner assigned to the project. If it is found that the project has the potential to affect an archeological resource, the PAR memorandum would identify any additional measures to be implemented. Such actions may include application of appropriate archeological mitigation measures and/or requiring additional archeological studies as part of the environmental evaluation. If an additional archeological study is required, it must be prepared by a qualified archeological consultant. The qualified consultant must be selected from a list of three archeological consultants from the Planning Department's archeological resources consultant file provided by the Planning Department during the environmental review process.⁴ The Planning Department Archeologist will be informed by the geotechnical study of the project site's subsurface geological conditions (see Item 11, Geology, below).

- 3. Transportation Impact Study.** Based on the Planning Department's transportation impact analysis guidelines, the project would potentially add approximately 514 PM peak-hour person trips, and thus

¹ San Francisco Planning Department. *South of Market Area Historic Resource Survey, Map of Historic Resource Survey Findings*, November 2, 2012. Available online at:

http://www.sf-planning.org/ftp/files/Preservation/soma_survey/SoMa_Survey_Findings_Map.pdf.

² San Francisco Planning Department. *South of Market Area Historic Resource Survey, California Historical Resource Status Codes*, December 8, 2003. Available online at:

http://sf-planning.org/ftp/files/gis/SouthSoMa/CHRSC_Status_Codes.pdf.

³ San Francisco Planning Department. *Eastern Neighborhoods Rezoning and Area Plans FEIR*, certified August 7, 2008. Available online at: <http://www.sf-planning.org/index.aspx?page=1893>.

⁴ San Francisco Planning Department. *Consultant Resources, Archeological Review Consultant Pool*. Available online at: <http://www.sf-planning.org/index.aspx?page=1886>

would most likely require a Transportation Impact Study (TIS).⁵ The TIS must be prepared by a qualified consultant working at the direction of the Planning Department staff. Upon submittal of an Environmental Evaluation Application and initiation of environmental review, the Planning Department will provide a Preliminary Consultant List with three transportation consultants qualified for preparing transportation impact analyses.

A formal determination as to whether a TIS is required will be made after submittal of the Environmental Evaluation Application. If a TIS is required, the Planning Department will provide additional guidance related to the process for selecting a transportation consultant and assist in the development of the scope of work for the analysis. The consultant must be selected from a list of three transportation consultants from the Planning Department's transportation consultant file provided by the Planning Department during the environmental review process.⁶

At the time of filing of the Environmental Evaluation Application, please ensure that the project description responds to the following comments:

- a. Clarify in the Environmental Evaluation Application and plans as to whether the proposed commercial gym on the first floor would be private or public;
- b. Show in the site plan the location of proposed bicycle parking spaces including Class II spaces within the fronting sidewalk. A minimum of 39 Class I bicycle spaces and 12 Class II bicycle spaces would be required;
- c. Show in the site plan the location of any proposed trash facilities;
- d. Clearly show in the site plan the location and width of all existing and proposed sidewalk and driveway(s);
- e. Clarify in the Environmental Evaluation Application and plans as to whether the proposed retail space can be occupied by a restaurant or café;
- f. Consider reducing parking supply due to proximity to existing and planned transit; and
- g. Ensure that the project is consistent with any changes in the transportation network proposed as part of the Central SoMa Plan.

The TIS must conform to the cumulative analysis in the Central SoMa Plan EIR, and may rely on some intersections and transit existing and plan data from the Central SoMa TIS; however, the project would be required to undertake its own project-level TIS that is modeled specifically for the proposed project.

4. **Noise.** Construction noise would be subject to the San Francisco Noise Ordinance (Article 29 of the San Francisco Police Code), which includes restrictions on noise levels of construction equipment and hours of construction. Detailed information related to construction equipment, phasing, and duration of each phase may be required as part of environmental evaluation to assess construction noise levels and methods to reduce such noise, as feasible.

⁵ Kei Zushi, San Francisco Planning Department. *Transportation Calculations*, July 9, 2014. These calculations are available for review as part of Case File No. 2014.0859U at the San Francisco Planning Department, 1650 Mission Street, Suite 400, San Francisco, California 94103.

⁶ San Francisco Planning Department. *Consultant Resources, Transportation Consultant Pool*. Available online at: <http://www.sf-planning.org/index.aspx?page=1886>

Based on the City's GIS-based traffic noise model map, the project site fronts a segment of Bryant Street with noise levels above 75 dBA L_{dn} (a day-night averaged sound level). In addition, the project site fronts a segment of Welsh Street with noise levels above between 60 and 65 dBA L_{dn} . The Land Use Compatibility Chart for Community Noise in the San Francisco General Plan, Environmental Protection Element states that construction of new residential use and new offices should generally be discouraged in an area with noise levels above 68 and 73 dBA L_{dn} , respectively, and that a detailed analysis of the noise reduction requirements must be made and needed noise insulation features included in the design of the building.⁷ The Land Use Compatibility Chart also indicates that construction of new retail space should be undertaken only after a detailed analysis of the noise reduction requirement is made and needed noise insulation features are included in the design. Based on this, a noise analysis prepared by a qualified acoustic consultant may be required for the project. A formal determination as to whether a noise analysis is required and as to the scope of the noise analysis will be made after submittal of the Environmental Evaluation Application.

5. Air Quality.

The proposed project at 112 dwelling units, 46,990 sf of office space, and 20,000 sf of retail space would be below the Bay Area Air Quality Management District's (BAAQMD) construction or operational screening level for criteria air pollutants.⁸ Therefore, an analysis of the project's criteria air pollutant emissions would likely not be required.

Project-related demolition, excavation, grading and other construction activities may cause wind-blown dust that could contribute particulate matter into the local atmosphere. To reduce construction dust impacts, the San Francisco Board of Supervisors approved the Construction Dust Control Ordinance (Ordinance 176-08, effective July 30, 2008) with the intent of reducing the quantity of dust generated during site preparation, demolition, and construction work in order to protect the health of the general public and of onsite workers, minimize public nuisance complaints, and to avoid orders to stop work by the Department of Building Inspection (DBI). Pursuant to the Construction Dust Control Ordinance, the proposed project would be required to prepare a Construction Dust Control Plan for review and approval by the San Francisco Department of Public Health (DPH).

In addition, San Francisco has partnered with the BAAQMD to inventory and assess air pollution and exposures from mobile, stationary, and area sources within San Francisco. Areas with poor air quality, termed the "Air Pollutant Exposure Zone," were identified. Land use projects within the Air Pollutant Exposure Zone require special consideration to determine whether the project's activities would expose sensitive receptors to substantial air pollutant concentrations. The proposed project is within an Air Pollutant Exposure Zone and includes sensitive land uses (i.e., dwelling units). Therefore, exhaust measures during construction and enhanced ventilation measures as part of building design will likely be required. Enhanced ventilation measures will be the same as those required for projects, such as this project, subject to Article 38 of the Health Code.⁹ Detailed information related to construction equipment, phasing and duration of each phase, and cubic yards of excavation shall be provided as part of the Environmental Evaluation Application.

⁷ San Francisco Planning Department. *San Francisco General Plan, Environmental Protection Element*. Available online at: http://www.sf-planning.org/ftp/general_plan/16_Environmental_Protection.htm

⁸ BAAQMD, *CEQA Air Quality Guidelines*, May 2011, Chapter 3.

⁹ Refer to <http://www.sfdph.org/dph/eh/Air/default.asp> for more information.

If the project would generate new sources of toxic air contaminants including, but not limited to: diesel generators or boilers, or any other stationary sources, the project would result in toxic air contaminants that may affect both on-site and off-site sensitive receptors. Given the proposed project's height of 130 feet, the proposed project would likely require a backup diesel generator and additional measures will likely be necessary to reduce its emissions. Detailed information related to any proposed stationary sources shall be provided with the Environmental Evaluation Application.

6. **Greenhouse Gas Emissions.** Potential environmental effects related to greenhouse gas (GHG) emissions from the project need to be addressed in a project's environmental evaluation. The project sponsor would be required to submit a completed GHG Compliance Checklist Table 1 for Private Development Projects demonstrating that the project is in compliance with the identified regulations and provide project-level details in the discussion column. This information will be reviewed by the environmental planner during the environmental review process to determine if the project would comply with San Francisco's Greenhouse Gas Reduction Strategy.¹⁰ Projects that do not comply with a GHG-related regulation may be determined to be inconsistent with San Francisco's Greenhouse Gas Reduction Strategy.
7. **Wind.** The proposed project would involve construction of construction of a 130-foot-tall, 11-story-over-basement, 216,880-sf building. The project would require an initial review by a wind consultant, including a recommendation as to whether a wind tunnel analysis is needed. The consultant would be required to prepare a proposed scope of work for review and approval by the Environmental Planning prior to the commencement of any required analysis.
8. **Shadow.** The proposed project would result in construction of a building 130 feet in height. A shadow fan analysis was prepared for this project.¹¹ The shadow analysis found that the proposed project would cast shadow on South Park, which is subject to the Planning Code Section 295. Further shadow analysis would be required for the Section 295 space as part of the environmental review for this project. The Planning Department will provide additional guidance related to the scope of the analysis after the Environmental Evaluation Application is filed.
9. **Flooding Potential.** The project site is in a block that has the potential to flood during storms.¹² Contact Cliff Wong of the San Francisco Public Utilities Commission (SFPUC) at (415) 554-8339 regarding the requirements below. Applicants for building permits for either new construction, change of use or change of occupancy, or for major alterations or enlargements shall be referred to the SFPUC at the beginning of the process, for a review to determine whether the project would result in ground level flooding during storms. The side sewer connection permits for such projects need to be reviewed and approved by the SFPUC at the beginning of the review process for all permit

¹⁰ City and County of San Francisco. *Strategies to Address Greenhouse Gas Emissions*. Available online at: http://sfmea.sfplanning.org/GHG_Reduction_Strategy.pdf.

¹¹ Chris Townes, San Francisco Planning Department. Preliminary Shadow Analysis: 565-585 Bryant Street (ref: 2014.0859U), July 13, 2014. This document is available for review as part of Case File No. 2014.0858U at the San Francisco Planning Department, 1650 Mission Street, Suite 400, San Francisco, California 94103.

¹² San Francisco Planning Department. *Planning Bulletin, Review of Projects in Identified Areas Prone to Flooding*, April 1, 2007. Available online at: <http://ec2-50-17-237-182.compute-1.amazonaws.com/docs/PlanningProvisions/info%20sheet%20v1.3.pdf>.

applications submitted to the Planning Department, the Department of Building Inspection, or Successor Agency to the Redevelopment Agency. The SFPUC and/or its delegate (SFDPW, Hydraulics Section) will review the permit application and comment on the proposed application and the potential for flooding during wet weather. The permit applicant shall refer to PUC requirements for information required for the review of projects in flood prone areas. Requirements may include provision of a pump station for the sewage flow, raised elevation of entryways, and/or special sidewalk construction and the provision of deep gutters.

10. **Recycled Water Ordinance.** The project site is subject to the Recycled Water Ordinance.¹³ New construction of 40,000 sf or more, or addition of 10,000 sf or more of irrigated space are required to include plumbing to supply recycled water.
11. **Geotechnical Study.** The project site is located in a Seismic Hazard Zone, specifically a liquefaction zone, as identified in the San Francisco General Plan. Any new construction on the project site is subject to a mandatory Interdepartmental Project Review because it is located within a Seismic Hazard Zone.¹⁴ A geotechnical study prepared by a qualified consultant must be submitted with the Environmental Evaluation Application. The study should address whether the site is subject to liquefaction, and should provide recommendations for any geotechnical concerns identified in the study. In general, compliance with the building codes, as assured through DBI's permit review process, would avoid the potential for significant impacts related to structural damage, ground subsidence, liquefaction, landslides, and surface settlement. This study will also help inform the Planning Department Archeologist of the project site's subsurface geological conditions.
12. **Stormwater Management.** If the project results in a ground surface disturbance of 5,000 sf or greater, it is subject to San Francisco's stormwater management requirements as outlined in the Stormwater Management Ordinance and the corresponding SFPUC Stormwater Design Guidelines (Guidelines). Projects that trigger the stormwater management requirements must prepare a Stormwater Control Plan demonstrating project adherence to the performance measures outlined in the Guidelines including: (a) reduction in *total volume* and *peak flow rate* of stormwater for areas in combined sewer systems; or (b) *stormwater treatment* for areas in separate sewer systems. Responsibility for review and approval of the Stormwater Control Plan is with the SFPUC, Wastewater Enterprise, Urban Watershed Management Program. Without SFPUC approval of a Stormwater Control Plan, no site or building permits can be issued. The Guidelines also require a signed maintenance agreement to ensure proper care of the necessary stormwater controls. The project's environmental evaluation should generally assess how and where the implementation of necessary stormwater controls would reduce the potential negative impacts of stormwater runoff. To view the Stormwater Management Ordinance, the Stormwater Design Guidelines, or download instructions for the Stormwater Control Plan, go to <http://sfwater.org/sdg>.
13. **Hazardous Materials.** The proposed sponsor has indicated that the amount or depth of soil disturbance involved in the proposed project is unknown at the time of this PPA. The project involves

¹³ San Francisco Public Utilities Commission (PUC). *Recycled Water Installation Procedures for Developers*.

Available online at: <http://ec2-50-17-237-182.compute-1.amazonaws.com/docs/PlanningProvisions/recy.pdf>.

¹⁴ San Francisco Planning Department. *Interdepartmental Project Review*. Available online at:

<http://www.sf-planning.org/Modules/ShowDocument.aspx?documentid=522>

a construction of an approximately 24,000-sf basement level. The project site is located within the Maher zone according to the Planning Department's GIS records. Based on this, the project would likely be subject to Article 22A of the Health Code, also known as the Maher Ordinance. The Maher Ordinance, which is administered and overseen by the San Francisco Department of Public Health (DPH), requires the project sponsor to retain the services of a qualified professional to prepare a Phase I Environmental Site Assessment (ESA) that meets the requirements of Health Code Section 22.A.6. The Phase I would determine the potential for site contamination and level of exposure risk associated with the project. Based on that information, soil and/or groundwater sampling and analysis, as well as remediation of any site contamination, may be required. These steps are required to be completed prior to the issuance of any building permit.

DPH requires that projects subject to the Maher Ordinance complete a Maher Application, available at: <http://www.sfdph.org/dph/EH/HazWaste/hazWasteSiteMitigation.asp>. Fees for DPH review and oversight of projects subject to the ordinance would apply. Please refer to DPH's fee schedule, available at: <http://www.sfdph.org/dph/EH/Fees.asp#haz>.

Please provide a copy of the submitted Maher Application and Phase I ESA with the Environmental Evaluation Application.

14. **Tree Disclosure Affidavit.** The Department of Public Works Code Section 8.02-8.11 requires disclosure and protection of landmark, significant, and street trees located on private and public property.¹⁵ Any tree identified in the Affidavit for Tree Disclosure must be shown on the Site Plans with the size of trunk diameter, tree height, and accurate canopy drip line. Please submit an Affidavit along with the Environmental Evaluation Application and ensure that trees are appropriately shown on site plans.
15. **Bird-Safe Building Ordinance.** The project would be subject to Planning Code Section 139, Standards for Bird-Safe Buildings, which addresses Location-Related Standards and Feature-Related Standards.¹⁶ The project's environmental evaluation would generally discuss how the implementation of bird-safe design standards would reduce potential adverse effects on birds due to the lighting, glazing, balconies, and so forth.
16. **Notification of a Project Receiving Environmental Review.** Notice is required to be sent to occupants of properties adjacent to the project site and owners of properties within 300 feet of the project site. Please be prepared to provide these mailing labels upon request during the environmental review process.

In order to begin formal environmental review, please submit an Environmental Evaluation Application.¹⁷ See "Studies for Project inside of Adopted Plan Areas" on page 10 of the current Fee Schedule for calculation of environmental application fees.¹⁸

¹⁵ San Francisco Planning Department. *Required Checklist for Tree Planting and Protection*. Available online at: <http://www.sf-planning.org/modules/showdocument.aspx?documentid=8321>.

¹⁶ San Francisco Planning Department. *Standards for Bird-Safe Buildings*. Available online at: <http://www.sfplanning.org/index.aspx?page=2506>.

¹⁷ San Francisco Planning Department. *Permit Forms*. Available online at: <http://www.sf-planning.org/index.aspx?page=2611>.

Within the CPE process, there can be three different outcomes as follows:

- (i) **CPE Only.** All potentially significant project-specific and cumulatively considerable environmental impacts are fully consistent with significant impacts identified in *the Central SoMa Plan EIR* ("*Central SoMa EIR*"), and there would be no new significant impacts peculiar to the proposed project. In these situations, all pertinent mitigation measures and CEQA findings from *the Central SoMa EIR* are applied to the proposed project, and a CPE checklist and certificate is prepared. With this outcome, the applicable fees are: (a) the CPE determination fee (currently \$13,339); (b) the CPE certificate fee (currently \$7,402); and (c) a proportionate share fee for recovery for costs incurred by the Planning Department for preparation of *the Central SoMa EIR*.
- (ii) **CPE + Focused Initial Study/Mitigated Negative Declaration.** If new site- or project-specific significant impacts are identified for the proposed project that were not identified in *the Central SoMa EIR*, and if these new significant impacts can be mitigated to a less-than-significant level, then a focused mitigated negative declaration is prepared to address these impacts, and a supporting CPE checklist is prepared to address all other impacts that were encompassed by *Central SoMa EIR*, with all pertinent mitigation measures and CEQA findings from *the Central SoMa EIR* also applied to the proposed project. With this outcome, the applicable fees are: (a) the CPE determination fee (currently \$13,339); (b) the standard environmental evaluation fee (which is based on construction value); and (c) a proportionate share fee for recovery for costs incurred by the Planning Department for preparation of *the Central SoMa EIR*.
- (iii) **CPE + Focused EIR.** If any new site- or project-specific significant impacts cannot be mitigated to a less-than-significant level, then a focused EIR is prepared to address these impacts, and a supporting CPE checklist is prepared to address all other impacts that were encompassed by *the Central SoMa EIR*, with all pertinent mitigation measures and CEQA findings from *the Central SoMa EIR* also applied to the proposed project. With this outcome, the applicable fees are: (a) the CPE determination fee (currently \$13,339); (b) the standard environmental evaluation fee (which is based on construction value); (c) one-half of the standard EIR fee (which is also based on construction value); and (d) a proportionate share fee for recovery for costs incurred by the Planning Department for preparation of *the Central SoMa EIR*.

PLANNING DEPARTMENT APPROVALS:

The project requires the following Planning Department approvals. These approvals may be reviewed in conjunction with the required environmental review, but may not be granted until after the required environmental review is completed. Note that the subject parcels are within the Central SoMa Plan area. The draft Plan was published in April 2013. The Central SoMa Plan process is anticipated to be completed by early 2015. The proposals in the draft Plan are subject to change and are contingent upon the eventual approval by the Planning Commission and Board of Supervisors.

1. **Rezoning.** The project site is located within the SLI (Service/Light Industrial) District. The proposed office and residential components of the proposed mixed-use project are not permitted under this

¹⁸ Ibid.

zoning designation, and the proposed Floor Area Ratio (FAR) exceeds the allowed maximum. In order for the project to proceed, the Planning Commission and Board of Supervisors would need to approve new zoning controls for the subject parcel.

The zoning concepts included in the Central Corridor Draft Plan indicate that a reclassification to MUO (Mixed-Use Office) is being considered for the site. The proposed mixed-use project, which includes office, residential and retail uses, would be permitted in MUO Zoning District, though the project may exceed the proposed FAR under this zone. Please see further discussion in the Preliminary Project Comments section.

2. **Height District Reclassification.** The project site is located within the 65-X Height and Bulk District. The height of the proposed project would exceed the existing height limit. In order for the project to proceed, the Board of Supervisors would need to approve a Height District Reclassification for the subject parcel.

The zoning concepts published in the Draft Plan indicate that a height limit of 85-130 feet (proposed High-Rise Alternative) is being considered for this site.

3. **Large Project Authorization** from the Planning Commission is required per Planning Code Section 329 for the new construction of a building greater than 75 feet in height or greater than 25,000 gross square feet. As proposed, the project will be required to seek specific Code modifications from the Planning Commission, for the following provisions:
 - a. Rear yard
 - b. Dwelling unit exposure
 - c. Open space
4. An **Office Allocation** from the Planning Commission is required per Planning Code Section 321 to establish more than 25,000 gross square feet of new office space.
5. A **Building Permit Application** is required for the demolition of the existing buildings on the subject property.
6. A **Building Permit Application** is required for the proposed new construction on the subject property.
7. A **Conditional Use application** would be required to consolidate lots, as per the draft Central SoMa Plan (Implementation Strategy 6.2). Conditional use evaluation will consider the emphasis of existing, smaller lot patterns in the massing of new buildings; the creation of new mid-block alleys or open space; delineation of uses that echoes smaller lot patterns; and other criteria.

Applications are available in the Planning Department lobby at 1650 Mission Street Suite 400, at the Planning Information Center at 1660 Mission Street, and online at www.sfplanning.org. Building Permit applications are available at the Department of Building Inspections at 1660 Mission Street.

NEIGHBORHOOD NOTIFICATIONS AND PUBLIC OUTREACH:

Project Sponsors are encouraged to conduct public outreach with the surrounding community and neighborhood groups early in the development process. Additionally, many approvals require a public

hearing with an associated neighborhood notification. Differing levels of neighborhood notification are mandatory for some or all of the reviews and approvals listed above.

This project is required to conduct a **Pre-application** meeting with surrounding neighbors and registered neighborhood groups before a development application may be filed with the Planning Department. The Pre-application packet, which includes instructions and template forms, is available at www.sfplanning.org under the "Permits & Zoning" tab. All registered neighborhood group mailing lists are available online at www.sfplanning.org under the "Resource Center" tab.

PRELIMINARY PROJECT COMMENTS:

The following comments address specific Planning Code and other general issues that may significantly impact the proposed project:

1. **Central SoMa Plan.** The subject property falls within the ongoing Central SoMa Plan study area generally bounded by 2nd, 6th, Townsend and Market Streets. The Draft Plan, published in April 2013, will be evaluated in an Environmental Impact Report (EIR). The Draft Plan will propose changes to the allowed land uses and building heights, and will include a strategy for improving the public realm in this area. The EIR, the Draft Plan, and the proposed rezoning and affiliated Code changes are anticipated to be before decision-makers for approval in mid-2015.

The Draft Plan includes recommendations for new land use controls as well as new height and bulk controls for the subject property. The Draft Plan is available for download at <http://centralsoma.sfplanning.org>. *Further comments in this section of the PPA are based on the Draft Plan concepts published to date.*

2. **Existing Zoning/Height and Bulk.** The subject property is located within the Service/Light Industrial (SLI) Zoning District, which does not permit office use. In this zone, low-income residential dwellings are only permitted subject to the approval of a Conditional Use Authorization, pursuant to Planning Code Section 803.8(b), otherwise residential use is not permitted. It is located within a 65-X Height and Bulk district, which does not permit the project's proposed height and bulk. *The project could not be approved under existing zoning.*
3. **Land Use.** The Draft Plan recommends rezoning the subject property to the Mixed-Use Office (MUO) zoning district, in which the proposed office, retail and residential uses would be allowed. These uses are generally consistent with key objectives of the Draft Plan, which include providing support for substantial development in a transit-rich area and favoring office development over other kinds of growth, particularly on large parcels.

In order to create a diverse and dynamic 24-hour neighborhood characteristic of SoMa, the Draft Plan's preliminary land use principles envision a mixed-use neighborhood in which substantial office development is balanced with retail, arts, entertainment, industrial, and residential uses. The proposed ground floor retail with upper floors devoted to office and residential uses support this vision of a mixed-use neighborhood and are strongly encouraged.

4. **Urban Form: Height, Bulk & Massing.** In recognition of the desire to accommodate more growth in the area, the Draft Plan recommends two height scenarios referred to as the Mid-Rise Alternative and

the High Rise Alternative. With regard to the subject site, the High-Rise Alternative proposes an 85-130 foot height limit.

The Eastern Neighborhoods Area Plan contains provisions for managing bulk. Whereas, the existing height and bulk designation of the subject property establishes a maximum building height of 65 feet with no bulk controls, the Draft Plan contains some initial concepts for bulk controls which will be refined as the planning process progresses. Currently, for buildings taller than 85 feet in height, the draft Plan would require a 15 foot setback from all property lines at a height roughly proportional to the width of the adjacent public right-of-way (or 85' adjacent to other properties). The proposed building does not appear to provide this proposed setback.

The Draft Central SoMa Plan (see Urban Form Implementation Strategy 6.2) restricts consolidation of small lots in order to maintain as sense of the area's urban fabric and lot pattern. As mentioned above in "Planning Department Approvals," to obtain a conditional use for lot consolidation under the draft plan, the project should demonstrate to the Planning Commission that the project design emphasizes small lot patterns with massing, opens spaces, existing buildings, multiple buildings and/or mid-block alleys.

5. **Floor Area Ratio (FAR).** The proposed project (FAR) of approximately 8.9 exceeds the maximum permitted 2.5 FAR under the existing SLI zoning designation. The Draft Plan proposed re-zoning of the subject property to MUO, where the maximum FAR based on the current Planning Code (for a height district over 85 feet) is 7.5 FAR, which the proposed project also exceeds. The specific FAR controls of the Central SoMa Plan have not yet been established. Department staff will continue refining the proposal for the Plan and working with project sponsors to develop projects that would be compliant with the proposed FAR controls.
6. **Eco-District.** An Eco-District is a neighborhood or district where residents, community institutions, property owners, developers, and businesses join together with City leaders and utility providers to meet sustainability goals and co-develop innovative projects at a district or block-level. The Planning Department has identified the Central SoMa Plan area as a Type 2 Eco-District. All major new development in the Plan area will be expected to participate in the Eco-District program and the Sustainability Management Association set up to guide it. Please see <http://www.sfplanning.org/index.aspx?page=3051> for more information.
7. **Large Project Authorization.** Planning Code Section 329 outlines the requirements for a Large Project Authorization in Eastern Neighborhoods Mixed Use Zoning Districts. A Large Project Authorization is required of new building construction exceeding 75 feet in height or 25,000 gross square feet. All large projects within the Eastern Neighborhoods Area Plan are subject to review by the Planning Commission in an effort to achieve the objectives and policies of the General Plan, the applicable Design Guidelines and the Planning Code. To the extent possible, the project should be designed to minimize deviations and should strive to comply with all Planning Code requirements. As proposed, the project will be required to seek specific Code modifications from the Planning Commission, for the following provisions:
 - a. **Rear Yard.** Planning Code Section 134 requires a minimum rear yard setback of 25% of the lot depth to be provided at the lowest story containing a dwelling unit, and at each succeeding level or story of the building. As proposed, all residential floors of the project about the rear

property line and; therefore, the project does not comply. Therefore, the project would be required to seek an exception from the Planning Commission as a component of the Large Project Authorization review process.

- b. **Dwelling Unit Exposure.** Planning Code Section 140 outlines requirements for all dwelling units to face an open area. All dwelling units shall feature a window that directly faces a public street, public alley, or side yard at least 25 feet in width, or a Code-compliant rear yard. As proposed, it appears that 58 of the proposed dwelling units do not meet the exposure requirement; therefore, the project would be required to seek an exception from the Planning Commission as a component of the Large Project Authorization review process. Please note that the Planning Department generally encourages that code-compliant exposure be provided for each dwelling unit. If an exposure modification is sought as part of the Large Project Authorization, the Planning Department generally encourages that the number of dwelling units seeking a modification be minimized.
- c. **Open Space (Residential/Non-Residential).** Planning Code Section 135 requires the project to provide 80 sf of open space for every dwelling unit (if non publically-accessible) and 54 sf of open space for every dwelling unit (if publically-accessible). Therefore, the total minimum required open space amount for the residential component is either 8,960 sf (80 sf x 112 du's = 8,960 sf) if not publically accessible or 6,048 sf (54 sf x 112 du's = 6,048 sf) if publically accessible.

Planning Code Section 135.3 requires this project to provide 1 sf of open space for every 250 sf of retail space, and 1sf of open space for every 50 sf of office space. With a total proposed office floor area of 42,660 sf, 853 sf of open space is required ($42,660 \text{ sf} / 50 = 852 \text{ sf}$). With a total of 20,000 sf of retail, 80 sf of open space is required ($20,000 \text{ sf} / 250 = 80 \text{ sf}$). The combined open space requirement for the office and retail component is 932 sf ($852 \text{ sf} + 80 \text{ sf} = 932 \text{ sf}$).

As proposed, the project provides approximately 4,652 sf of non-publically accessible open space at the 6th Floor terrace for office, and 910 sf of non-publically accessible open space at the 8th Floor. The project provides 2,024 sf of publically accessible open space at the ground floor courtyard. Therefore, the proposed amount of open space does not meet Code.

Please be aware that while under the Current Planning Code the non-residential open space is not required to be open to the public, the Central Corridor Plan proposes to require open space to be open to the public. As such, required non-residential open space should be preferably at-grade, easily accessible and visible to the public, and activated with adjacent uses, and at minimum meet the design and access requirements of Planning Code Section 138.

Since the project does not meet the minimum required open space requirements, it would be required to seek an exception from the Planning Commission as a component of the Large Project Authorization review process.

8. **Interdepartmental Project Review.** The subject property falls within a seismic hazard zone. An Interdepartmental Project Review is required for all proposed new construction in seismic hazard zones. An application is available in the Planning Department lobby at 1650 Mission Street, Suite 400

or at the Planning Information Center (PIC) at 1660 Mission Street, and online at www.sfplanning.org.

9. **Office Development Authorization.** Since the proposed project involves the new construction of over 25,000 sf of office space, the proposed project would need to obtain an Office Development Authorization from the Planning Commission, as outlined in Planning Code Section 321. Please be advised that if all pending office applications were to proceed, the office limit would be exceeded.
10. **Street Trees/Streetscape Plan.** Planning Code Section 138.1 outlines the requirements for streetscape and pedestrian improvements, including the requirement for new street trees and a streetscape plan.

The proposed project would be required to provide one street tree for every 20 feet of frontage for new construction with any remaining fraction of 10 feet or more of frontage requiring an additional tree, as well as the submittal of a streetscape plan. Therefore, the Project would be required to provide 8 street trees along Bryant Street. The project plans do not provide any street trees, and therefore the project does not comply with this provision. The applicant may seek a waiver from the street tree requirement subject to Zoning Administrator approval. To receive a preliminary street tree waiver assessment, the applicant should submit a Tree Referral Form (see attached) to the Department of Public Works (DPW).
11. **Bird Safety.** Planning Code Section 139 outlines the standards for new construction to reduce bird mortality and bird hazards. Please refer to these standards to ensure compliance with the Standards for Bird-Safe Buildings.
12. **Street Frontage.** As new construction located within an Eastern Neighborhoods Mixed Use District, the proposed project would be subject to the requirements for street frontage, as outlined in Planning Code Section 145.1, including the requirements for active uses, ground floor ceiling heights, transparency and fenestration, among others. Please refer to Planning Code Section 145.1.
13. **Parking.** Under current zoning (SLI) and the potential zoning under the Central Corridor planning process (MUO), no parking would be required. However, each of these zoning districts would have parking maximums, which are listed in Planning Code Section 151.1. Within the MUO zoning district, parking is limited to up to seven percent of the gross floor area of office use, up to one parking space for every four dwelling units, and up to one parking space for every 1,500 sf of retail. Based on the existing and future transit accessibility of the site and the need to limit traffic volumes in the area, parking should be minimized on site.
14. **Loading.** Per Planning Code Section 152.1, the proposed project is required to provide one off-street freight loading parking space for the 20,000 sf of retail space. Please specify how many off-street freight loading parking spaces would be provided as part of the proposed project.
15. **Bicycle Parking.** Planning Code Section 155.1-155.4 provides requirements for bicycle parking and associated facilities (i.e. showers and lockers) in new commercial development. Based on the proposed areas which includes 112 dwelling units, 42,660 sf of office, 20,000 sf of retail, the proposed project is required to provide a minimum of 115 Class I bicycle parking spaces and 16 Class II bicycle parking spaces. Please specify how many bicycle parking spaces (per type) will be provided as part of the proposed project and ensure compliance with required associated facilities.

16. **Eastern Neighborhoods Impact Fees.** Pursuant to Planning Code Section 423, the Eastern Neighborhoods Impact Fee applies to the Project. Impact fees shall be assessed per net new gross square footage on residential and non-residential uses within the Plan Area. Impact fees shall be assessed on mixed-use projects according to the gross square feet of each use in the project. Please note that the Eastern Neighborhoods Fee Tier applicable to this project will be revised upon any rezoning of the property to increase height limits, density allowances, or allowed uses, such as would be necessary for the proposed project to proceed. The Central Corridor Plan as envisioned will maintain the Eastern Neighborhoods Impact Fee structure and add, as necessary, one or more additional higher fee tiers, reflective of the greater heights and densities envisioned in the Central Corridor Plan.

The Eastern Neighborhoods Impact Fee shall be paid before the City issues a first construction document, with an option for the project sponsor to defer payment to prior to issuance of the first Certificate of Occupancy upon agreeing to pay a deferral surcharge in accordance with Section 107A.13.3 of the San Francisco Building Code.

Option for In-Kind Provision of Community Improvements and Fee Credits. Project sponsors may propose to directly provide community improvements to the City. In such a case, the City may enter into an In-Kind Improvements Agreement with the sponsor and issue a fee waiver for the Eastern Neighborhoods Impact Fee from the Planning Commission. This process is further explained in Section 412.3(d) of the Planning Code. More information on in-kind agreements can be found in the Application Packet for In-Kind Agreement on the Planning Department website.

17. **Jobs-Housing Linkage Program.** Pursuant to Planning Code Section 413 et seq., the Jobs-Housing Linkage Program fee will apply to this project since the proposed office area exceeds 25,000 sf.
18. **Transit Impact Development Fee.** Pursuant to Planning Code Section 411 et seq., the Transit Impact Development Fee will apply to this project. Please be aware that an ongoing process – the Transportation Sustainability Program may eventually replace the Transit Impact Development Fee. You can find more information about this program here:
<http://www.sf-planning.org/index.aspx?page=3035>
19. **Affordable Housing.** Pursuant to Planning Code Section 415, any housing project which consists of ten or more dwelling units shall satisfy the Inclusionary Housing Program requirements outlined in Planning Code Section 415.3(b), Table 415.3. Table 415.3 provides alternatives which include payment of a 20% fee, providing 12% (of the total # of units) on-site as affordable, or 20% (of the total # of units) off-site as affordable. Please see Planning Code Section 415 for further Inclusionary Housing Program Code requirements which may also include submission of an Affidavit of Compliance to the Planning Department depending on the alternative sought. Any on-site affordable dwelling-units proposed as part of the project must be designated as owner-occupied units, not rental units. Affordable units designated as on-site units shall be sold as ownership units and will remain as ownership units for the life of the project.

For your information, if a project proposes rental units, it may be eligible for an On-site Alternative to the Affordable Housing Fee if it has demonstrated to the Planning Department that the affordable units are either: 1) ownership only or 2) not subject to the Costa Hawkins Rental Housing Act (a

Costa Hawkins exception). Affordable units are not subject to the Costa Hawkins Rental Housing Act under the exception provided in Civil Code Sections 1954.50 through one of the following methods:

- a. Direct financial construction from a public entity
- b. Development bonus or other form of public assistance

A Costa Hawkins exception agreement is drafted by the City Attorney. You must state in your submittal how the project qualifies for a Costa Hawkins exception. The request should be addressed to the Director of Current Planning. If the project is deemed eligible, we may start working with the City Attorney on the agreement.

The Draft Plan (see Strategy 2.3 in the Funding chapter) states that parcels rezoned from SLI as well as parcels receiving significant height increases will be required to provide increased affordable housing above the City's baseline inclusionary housing program. The rates are subject to ongoing study.

20. **Public Art.** Pursuant to Planning Code Section 429 et seq., this project will be subject to the public art requirements, since it involves new construction in excess of 25,000 sq. ft. within the SLI or MUO Zoning Districts.
21. **First Source Hiring Agreement.** A First Source Hiring Agreement is required for any project proposing to construct 25,000 gross square feet or more. For more information, please contact:

Ken Nim, Workforce Compliance Officer
CityBuild, Office of Economic and Workforce Development
City and County of San Francisco
1 South Van Ness, San Francisco, CA 94102
Direct: 415.701.4853, Email: ken.nim@sfgov.org
Fax: 415.701.4897
Website: <http://oewd.org/Workforce-Development.aspx>

PRELIMINARY DESIGN COMMENTS:

The project is located south of Market Street in a neighborhood with a variety of industrial, residential and commercial uses. The adjacent context includes one to seven story buildings with primarily industrial or residential character. The project also faces streets with very different scales and character: Bryant Street is a wide, busy, and more commercial street and Welsh is a small, quiet, more residential one. The following comments address preliminary design issues that may significantly impact the proposed project:

1. **Site Design, Open Space, and Massing.** There are two bulk and massing requirements of the existing and proposed Central SoMa area plan that are not currently included in the proposal: a 15' setback from all lot edges above 85' and Planning Code Section 162.1 which requires a 10' setback at 1.25 times the height on the northerly side of specifically identified small streets (including Welsh).

In response to these required modifications, the Planning Department recommends inverting the proposed building massing such that there is a stronger streetwall presented to the Bryant Street side and a softer more diminutive massing along Welsh. While the proposed project aims to keep the

more piecemeal elements of a consolidated lot configuration, the Planning Department prefers a stronger street wall where this requirement could be formed by smaller massing breaks or architectural articulation in rhythm with the existing or neighboring building patterns.

The Planning Department appreciates the inclusion of the POPOS on the ground level and suggests that it be combined or reconfigured on the site to include a mid-block alley as the block is over 440 feet and in the mid portion of the block. This could help animate Welsh as a more dynamic pedestrian area.

See Preliminary Project Comment #4 above (“Urban Form: Height, Bulk & Massing”) and Draft Central SoMa Plan Urban Form Strategy 6.2 for strategies to echo existing lot patterns and scale in the neighborhood.

2. **Street Frontage.** The Planning Department recommends providing clear and direct access from the proposed “commercial gym” space to Welsh. Additional entries could be integrated with a mid-block alley so that they could be mutually supportive of active use. Otherwise, the Planning Department supports the project’s retail proposal and further encourages retail access from a potential mid-block alley. Additionally, UDAT encourages the introduction of balconies or Juliet balconies on the lower level floors, in particular the lower residential levels.

The Planning Department recommends a maximum garage curbcut and driveway width of 20’.

3. **Architecture.** The Planning Department has no comments on the architecture at this time as the project is diagrammatic however we encourage the future architecture respond in a contemporary way to the neighboring and existing context in rhythm, texture, and character.

PRELIMINARY PROJECT ASSESSMENT EXPIRATION:

This Preliminary Project Assessment is valid for a period of **18 months**. An Environmental Evaluation, Conditional Use Authorization, or Building Permit Application, as listed above, must be submitted no later than **January 22, 2016**. Otherwise, this determination is considered expired and a new Preliminary Project Assessment is required. Such applications and plans must be generally consistent with those found in this Preliminary Project Assessment.

Enclosure: Neighborhood Group Mailing List
SFPUC Recycled Water Information Sheet

cc: Henry and Wilma Forcade FLP, Property Owner
John Kevlin, Reuben, Junius & Rose, LLP
Christopher Townes, Current Planning
Kei Zushi, Environmental Planning
Maia Small, Design Review

FIRST	LAST	TITLE	ORGANIZATION	ADDRESS	CITY	STATE	ZIP	TELEPHONE	EMAIL	NEIGHBORHOOD OF INTEREST
Angelica	Cabande	Organizational Director	South of Market Community Action Network (SOMCAN)	1110 Howard Street	San Francisco	CA	94103		0 acabande@somcan.org	South of Market
Antonio	Diaz	Project Director	People Organizing to Demand Environmental and Economic Rights (PODER)	474 Valencia Street #125	San Francisco	CA	94103	415-431-4210	podersf.org	Excelsior, Mission, South of Market
Carolyn	Diamond	Executive Director	Market Street Association	870 Market Street, Suite 456	San Francisco	CA	94102	415-362-2500	msadv@pacbell.net	South of Market
Corinne	Woods	0	Mission Creek Harbor Association	300 Channel Street, Box 10	San Francisco	CA	94158	415-902-7635	corinnewoods@cs.com	Potrero Hill, South of Market
Don	Falk	Executive Director	Tenderloin Neighborhood Development Corporation	201 Eddy Street	San Francisco	CA	94102	415-776-2151	dfalk@tndc.org; ceddings@tndc.org	Downtown/Civic Center, Haight Ashbury, Inner Sunset, Mission, Outer Sunset, South of Market
Gerald	Wolf	President	Hallam Street Homeowners Association	1 Brush Place	San Francisco	CA	94103	415-626-6650	wolfgk@earthlink.net	South of Market
Ian	Lewis	0	HERE Local 2	209 Golden Gate Avenue	San Francisco	CA	94102		0	0 Chinatown, Downtown/Civic Center, Marina, Mission, Nob Hill, North Beach, Pacific Heights, Presidio, South of Market
Jane	Kim	Supervisor, District 6	Board of Supervisors	1 Dr. Carlton B Goodlett Place, Room #244	San Francisco	CA	94102-4689	415-554-7970	jane.kim@sfgov.org; April.veneracion@sfgov.org; Sunny.Angulo@sfgov.org; lvy.Lee@sfgov.org	Downtown/Civic Center, North Beach, South of Market, Treasure Island/YBI
Janet	Carpinelli	Board President	Dogpatch Neighborhood Association	934 Minnesota Street	San Francisco	CA	94107	415-282-5516	jc@jcarpinelli.com	Potrero Hill, South of Market
Jason	Henderson	Vice Chariman	Market/Octavia Community Advisory Comm.	300 Buchanan Street, Apt. 503	San Francisco	CA	94102	415-722-0617	jhenders@sbcglobal.net	Castro/Upper Market, Downtown/Civic Center, Mission, South of Market, Western Addition
Jim	Meko	Chair	SOMA Leadership Council	366 Tenth Street	San Francisco	CA	94103	415-552-2401	jim.meko@comcast.net	Mission, South of Market
Katy	Liddell	President	South Beach/Rincon/ Mission Bay Neighborhood Association	403 Main Street #813	San Francisco	CA	94105	415-412-2207	kliiddell2001@yahoo.com	South of Market
Kaye	Griffin	Director	LMNOP Neighbors	1047 Minna Street	San Francisco	CA	94103	415-724-1953	LMNOP@yak.net	South of Market
Keith	Goldstein	0	Potrero-Dogpatch Merchants Association	800 Kansas Street	San Francisco	CA	94107		0 keith@everestsf.com	Mission, Potrero Hill, South of Market
Laura	Magnani	0	American Friends Service Committee	65 Ninth Street	San Francisco	CA	94103	415-565-0201	sfoffice@afsc.org	South of Market
Marvis	Phillips	Land Use Chair	Alliance for a Better District 6	230 Eddy Street #1206	San Francisco	CA	94102-6526	415-674-1935	marvisphillips@gmail.com	Downtown/Civic Center, Mission, South of Market, Western Addition
Patsy	Tito	Executive Director	Samoan Development Centre	2055 Sunnydale Avenue #100	San Francisco	CA	94134-2611		0	0 Bayview, South of Market
Reed	Bement	President	Rincon Hill Residents Association	75 Folsom Street #1800	San Francisco	CA	94105	415-882-7871	rbement@sbcglobal.net	South of Market
Rodney	Minott	Chair	Potrero Hill Neighbors/Save the Hill	1206 Mariposa Street	San Francisco	CA	94107	415-553-5969	rodminott@hotmail.com	Potrero Hill, South of Market
Sonja	Kos	Community Advocate	TODCO Impact Group	230 Fourth Street	San Francisco	CA	94103	415-426-6819	sonja@todco.org	South of Market
Tiffany	Bohee	Executive Director	Office of Community Investment and Infrastructure, City and County of San Francisco	1 South Van Ness Avenue, 5th Floor	San Francisco	CA	94103		0 tiffany.bohee@sfgov.org; mike.grisso@sfgov.org; courtney.pash@sfgov.org	Bayview, Downtown /Civic Center, South of Market, Visitacion Valley
Tony	Kelly	President	Potrero Boosters Neighborhood Association	1459 - 18th Street, Suite 133	San Francisco	CA	94107	415-861-0345		0 Mission, Potrero Hill, South of Market
York	Loo	0	York Realty	243A Shipley Street	San Francisco	CA	94107-1010	415-751-8602	yorkloo@gmail.com	South of Market



San Francisco Public Utilities Commission Recycled Water Installation Procedures for Developers

The City and County of San Francisco (CCSF) requires property owners to install dual-plumbing systems for recycled water use in accordance with Ordinances 390-91, 391-91, and 393-94, within the designated recycled water use areas under the following circumstances:

- New or remodeled buildings and all subdivisions with a total cumulative area of 40,000 square feet or more
- New and existing irrigated areas of 10,000 square feet or more

The following are procedures to guide developers and property owners with the installation of recycled water service lines. The diagram on the reverse shows how, and where the lines are to be installed, and the required backflow prevention assembly.

Number of Water Lines Coming onto a Property

Three to four lines:

- 1) Fire
- 2) Potable water domestic
- 3) Recycled water domestic
- 4) Recycled water irrigation (if property has landscaping)

Number of Water Meters

One water meter is required for each water line.

Required Backflow Prevention Assembly

Fire line – reduced pressure principle backflow preventer

Potable water domestic – reduced pressure principle backflow preventer

Recycled water domestic – reduced pressure principle backflow preventer

Recycled water irrigation line – reduced pressure principle backflow preventer

All backflow prevention assemblies must be approved by the SFPUC's Water Quality Division.

The backflow prevention assembly for domestic water plumbing inside the building and for the recycled water system must meet the CCSF's Plumbing Code and Health Code.

Pipe Separation

California Department of Public Health regulations require new water mains and new supply lines to be installed at least 4-foot horizontally from, and one-foot vertically above a parallel pipeline conveying recycled water.

Pipe Type

- Transmission lines and mains – ductile iron
 - Distribution and service lines – purple PVC or equivalent
 - Irrigation lines – purple PVC or equivalent
 - Dual-plumbing – described in the City and County of San Francisco Plumbing Codes
- **SFPUC must sign off on pipe type prior to installation.** Contact the City Distribution Division at (415) 550-4952.

Temporary Potable Water Use Until Recycled Water Becomes Available

The potable water line will be used to feed the recycled water lines(s) until such time that recycled water becomes available. When recycled water becomes available, the cross-connection will be broken by the SFPUC, and the potable and recycled water lines will be totally separated. Before recycled water is delivered to the property, cross-connection and backflow testing will take place to assure separation.

Under no circumstances are developers or property owners to "t-off" of the potable water line to the recycled water lines(s).

If you have questions, or would like additional information:

Recycled Water Ordinances and Technical Assistance

San Francisco Public Utilities Commission
Water Resources Division
(415) 554-3271

Backflow Prevention

San Francisco Public Utilities Commission
Water Quality
(650) 652-3100

Recycled Water Plumbing Codes

Department of Building Inspection
Plumbing Inspection Services
(415) 558-6054

New Service Line Permits

San Francisco Public Utilities Commission
Customer Services
(415) 551-3000

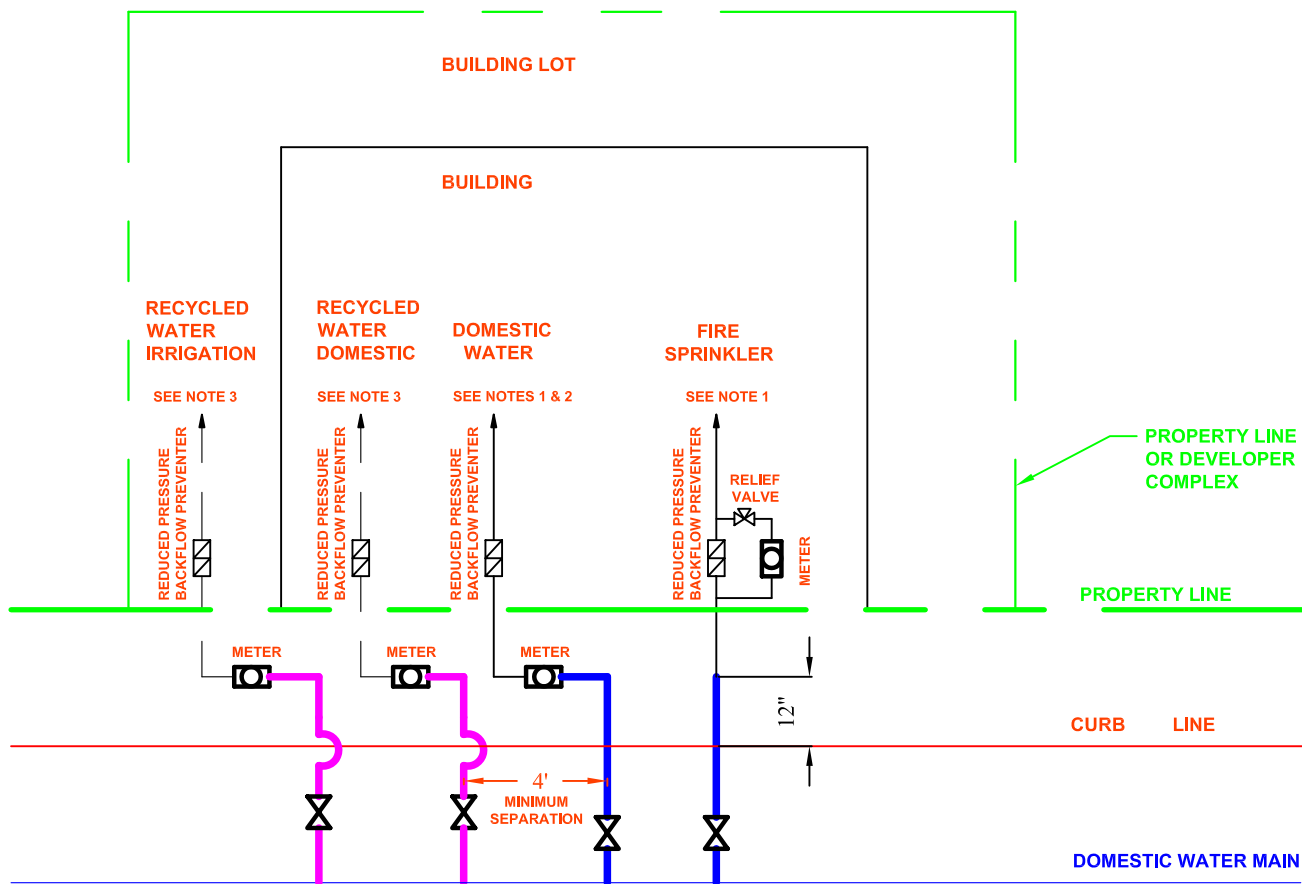

STREET - SIDE

NOTE:

1. ALL BACKFLOW PREVENTERS MUST APPROVED BY SFPUC WATER QUALITY BUREAU.
2. BACKFLOW PREVENTION FOR DOMESTIC WATER PLUMBING INSIDE THE BUILDING MUST MEET CCSF PLUMBING CODE AND PUBLIC HEALTH CODE REQUIREMENTS.
3. BACKFLOW PREVENTER FOR RECYCLED WATER SYSTEM MUST MEET CCSF PLUMBING CODE AND PUBLIC HEALTH CODE REQUIREMENTS.

RESPONSIBILITY OF INSTALLATION OF

HEAVY LINES:

PROPERTY OWNER PAYS FOR NEW SERVICE INSTALLATION. SFPUC RETAINS OWNERSHIP OF NEW SERVICE UP TO THE END OF METER ASSEMBLY.

LIGHT LINES: & _____

PROPERTY OWNER PAYS FOR NEW SERVICE INSTALLATION. OWNERSHIP REMAINS WITH THE PROPERTY OWNER.

CITY AND COUNTY OF SAN FRANCISCO
PUBLIC UTILITIES COMMISSION
SAN FRANCISCO WATER DEPARTMENT

INSTALLATION OF RECYCLED WATER SERVICE LINES

APPROVED BY:

SCALE:

NTS

DESIGNED BY:
Cheryl Munoz

DATE: 05/28/08

DRAWN: W.Villasica

CHECKED: M.Gardiner

DRAWING NO.
A-1290.2
REV. NO. 2